

# Technical Bulletin

Bulletin Number: 364 Revision Number: R-02

Release Date: June 28, 1988 Revision Date: October 27, 1998

**SUBJECT:** HINGES - MAIN DOOR

**MODELS:** All DNCB and FlexPak (DMV) Models

**SERIAL BREAK:** See Index Below.

**REASON:** To provide a list of hinges and their usage.

## INDEX

<b>Top Hinges - Assy. Views of New and Old</b> .....	Page 2
DNCB E-Models .....	Page 3
DNCB T-Models / Standard Models.....	Page 3
DMV (FlexPak) .....	Page 4
<b>Bottom Hinges - Assy. Views of New DNCB and Old DNCB</b> .....	Page 5
DNCB E-Models .....	Page 6
DNCB T-Models / Standard Models.....	Page 7
DMV (FlexPak) .....	Pages 8, 9, and 10
<b>Anti-Vandal Sleeve / Hinge Kit for DNCB Prior to 0001-3049BU</b> .....	Pages 11 and 12
Top Hinge Sleeve .....	Page 11
Bottom Hinge Sleeve.....	Page 12

# TOP HINGES

New Drop In Hinge Pin Style  
801,304,93x.x1  
or  
801,304,92x.x1

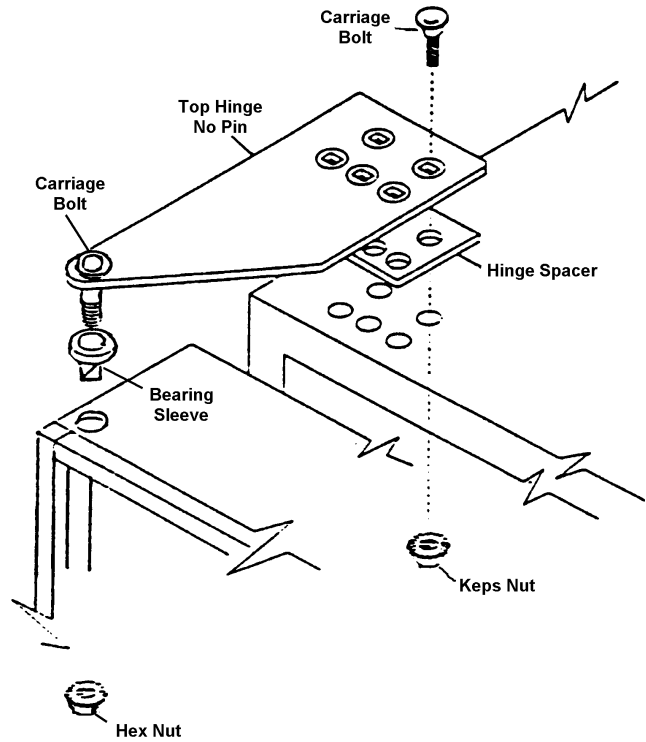

Old Style, Replaced by Above.

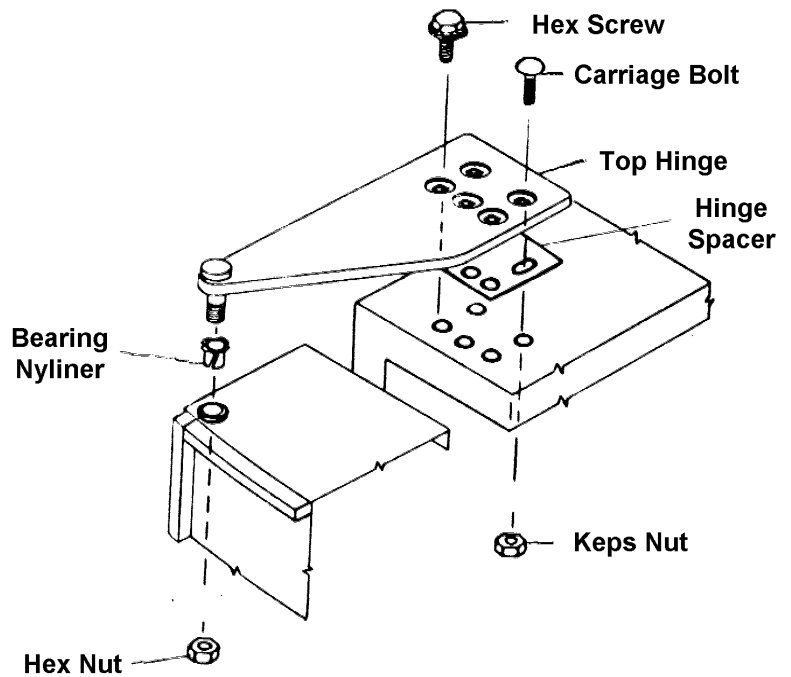

## TOP HINGE MAIN DOOR - DNCB

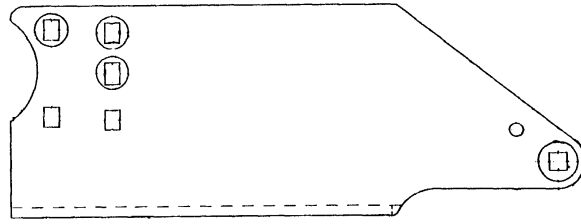

Top Hinge Main Door No Pin - E-Models  
801,304,93x.x1  
s/n 1615-6415BV to 0814-6452AW

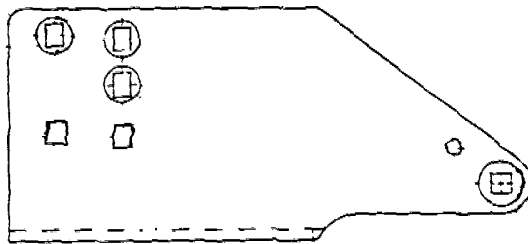

Top Hinge Main Door No Pin  
T-Models and Standard Models  
801,304,92x.x1  
s/n 0633-6417BV & up - T-Model & Standard Models  
0814-6452AW & up - E-Models

### OTHER TOP HINGES

- |                |   |
|----------------|---|
| 609,050,20x.x3 | Top Hinge Assy., E-Models (s/n 0001-6317AU to 1615-6415BV)<br>Replaced by 801,304,93x.x1            |
| 497,050,10x.x3 | Top Hinge Assy., DNCB T and Standard (s/n 0001-6300AU to 0633-6417BV)<br>Replaced by 801,304,92x.x1 |
| 801,304,88x.x1 | Top Hinge Assy. E-Models (s/n 0001-6368DU to 0001-6317AU)<br>Replaced by 801,304,93x.x1             |
| 801,304,67x.x1 | Top Hinge Assy., DNCB (s/n 0001-6300AU to 0633-6417BV)<br>Replaced by 801,304,92x.x1                |
| 801,303,73x.x1 | Top Hinge, DNCB T and Standard (s/n 0001-2392CE to 0001-6300AU)                                     |
| 801,501,71x.x1 | Top Hinge, DNCB T and Standard (s/n prior to 0001-2392CE)<br>Replaced by 801,304,92x.x1             |

# TOP HINGE ASSY. FLEXPAK (DMV)

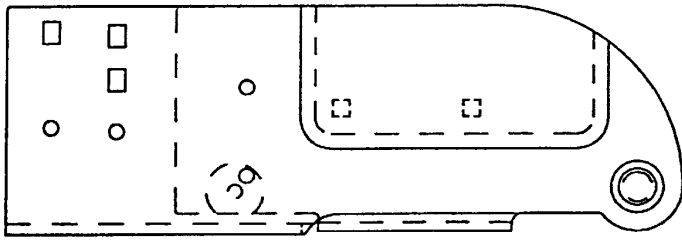

Top Cabinet Hinge

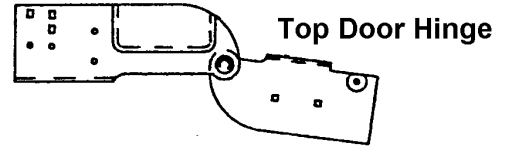

Extended Top Hinge Assy. - DMV  
 801,304,54x.x1  
 s/n 0175-6259DT through 0750-6360DU  
 (except 0494 to 0500-6258BT)

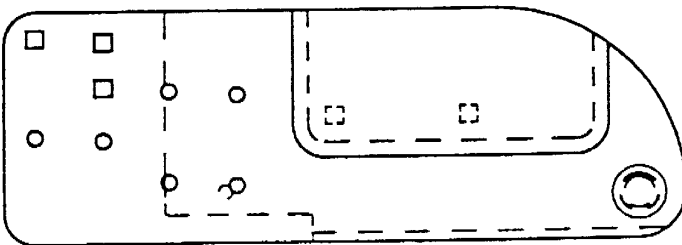

Top Cabinet Hinge



Extended Top Hinge Assy. - DMV  
 801,304,47x.x1  
 s/n 0175-6259DT through 0750-6360DU

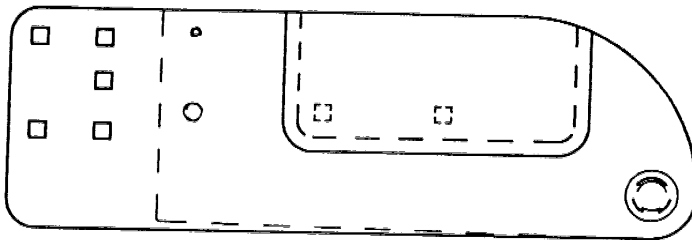

Top Cabinet Hinge



Extended Top Hinge Assy. - DMV  
 801,304,17x.x1  
 s/n 0494 to 0500-6258BT

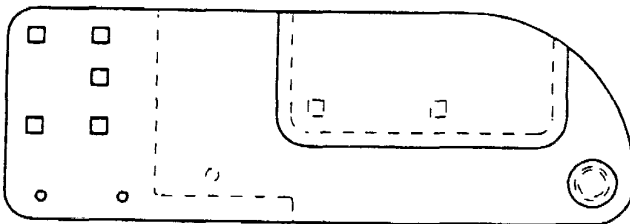

Top Cabinet Hinge

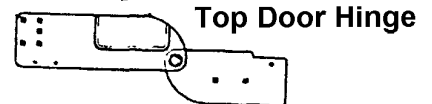

Extended Top Hinge Assy. - DMV  
 801,304,33x.x  
 s/n 0001 to 0174-6259CT  
 0494 to 0500-4074

# BOTTOM HINGE

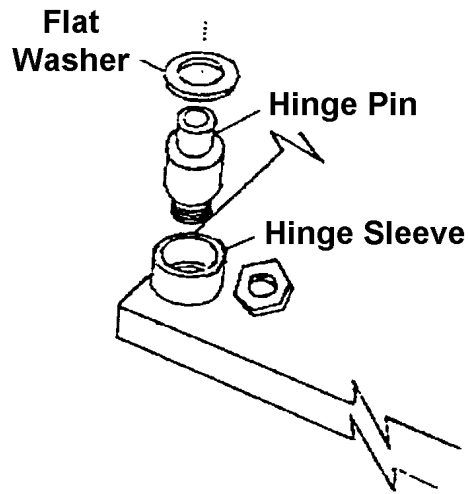

900,502,70x.x1  
Hinge Pin  
0001-3049BM and up

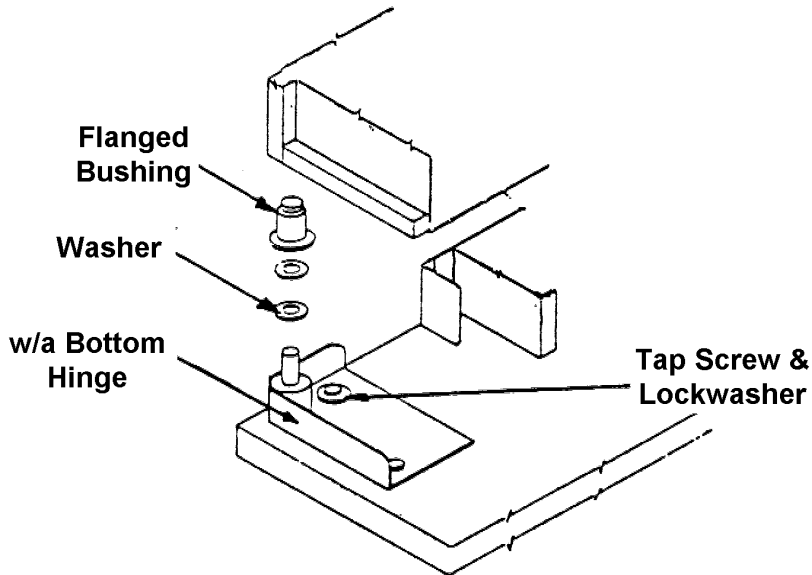

169,000,10x.x3  
w/a Bottom Hinge  
prior to 0001-3049BM

## BOTTOM HINGE MAIN DOOR - DNCB E-MODELS

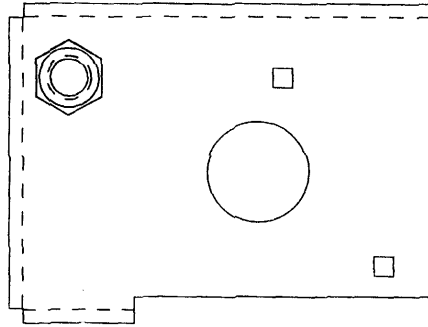

Bottom Hinge Main Door - E-Model  
801,305,08x.x1  
s/n 0814-6452AW and up  
s/n 0001-6368DU to 0814-6452AW

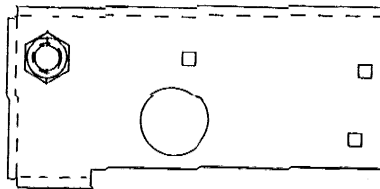

Bottom Hinge Main Door - E-Models  
s/n 0001-6368DU to 0814-6452AW

---

## BOTTOM HINGE PIN - DNCB

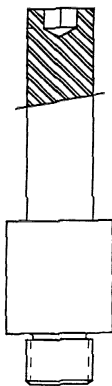

Hinge Pin - E-Models  
900,502,70x.x1  
s/n 0001-6368DU to 0814-6452AW

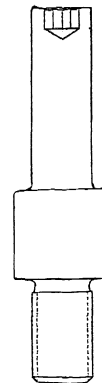

Hinge Pin - E-Models  
800,502,93x.x1  
s/n 0814-6452AW and up  
s/n 0001-6368DU to 0814-6452AW

# BOTTOM HINGE MAIN DOOR - DNCB T AND STANDARD

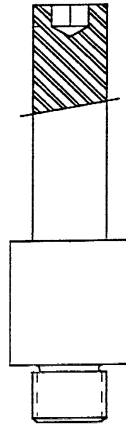

Hinge Pin T & Standard  
900,502,70x.x1  
s/n 0001-3049BM and up  
(except runs 3057CM & 3058CM)

## OBSOLETE HINGE PINS

900,502,58X.X1 Bottom Hinge Pin (s/n 0001-3049BM and up)  
Replaced by 900,502,70x.x1

900,502,65x.x1 Bottom Hinge Pin (s/n 0001-3049BM and up)  
Replaced by 900,502,70x.x1

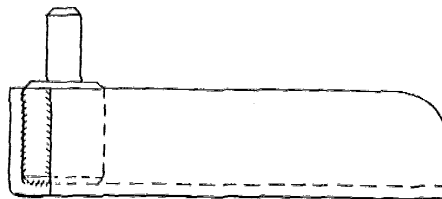
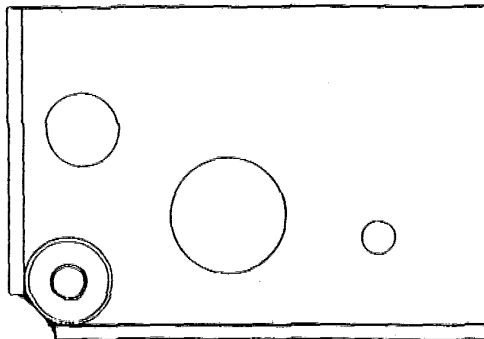

w/a Bottom Hinge  
169,000,10x.x3  
s/n prior to 0001-3049BM  
(Includes production runs 3057CM & 3058CM)

# BOTTOM HINGES DOOR FLEXPAK (DMV)

Top View

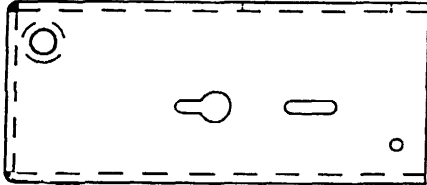

Side View

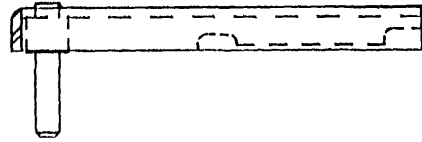

Extended Bottom Door Hinge Assy. - DMV  
801,304,45x.x1  
s/n 0001-6269DT & up

Top View

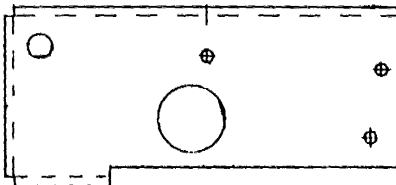

Extended Bottom Cabinet Hinge - DMV  
801,304,42x.x1  
s/n 0001-6269DT & up

Top View

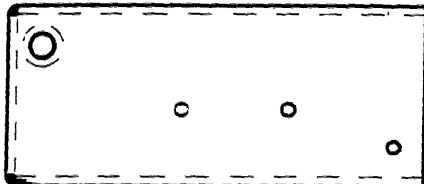

Side View

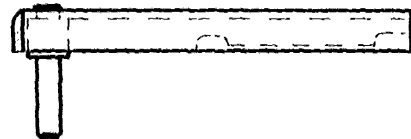

Extended Bottom Door Hinge Assy. - DMV  
801,304,48x.x1  
s/n 0156 to 0175-6259CT



# BOTTOM HINGES DOOR FLEXPAK (DMV)

Top View

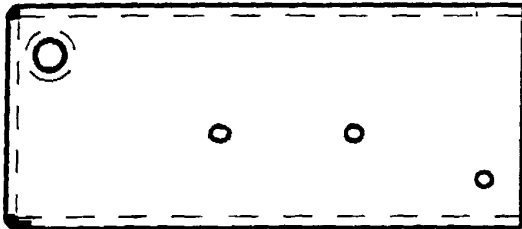

Side View

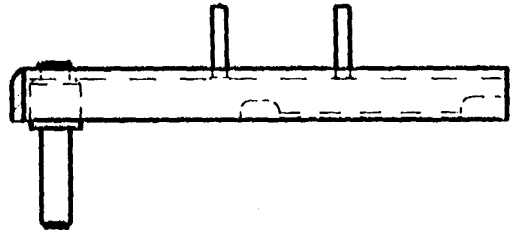

Extended Bottom Door Hinge Assy. - DMV  
801,304,37x.x1  
s/n 001 to 010-4074  
001 to 0175-6259CT

Top View

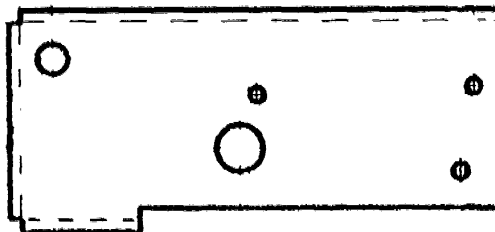

Extended Bottom Cabinet Hinge - DMV  
801,304,32x.x1  
s/n 001 to 010-4074  
001 to 0175-6259CT

# BOTTOM HINGES DOOR FLEXPAK (DMV)

Top View

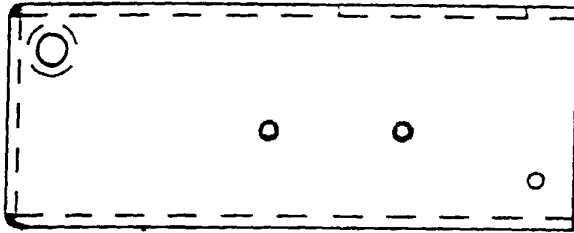

Side View

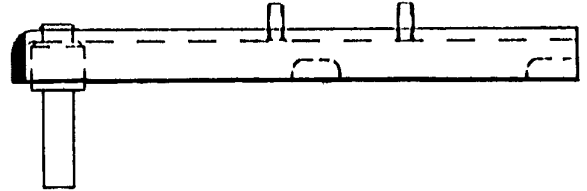

Extended Bottom Door Hinge Assy. - DMV  
801,304,18x.x1  
s/n 494 to 500-6258BT

Top View

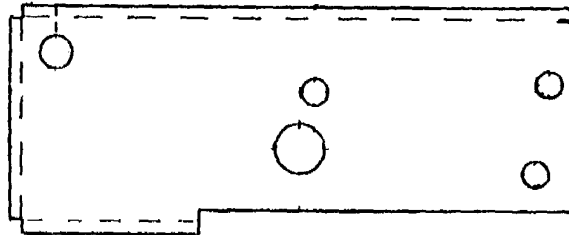

Extended Bottom Cabinet Hinge - DMV  
801,304,23x.x1  
s/n 494 to 500-6258BT

# ANTI-VANDAL SLEEVE / HINGE KIT PRIOR TO 0001-3049BM (INCLUDES 3057CM AND 3058CM)

## Bottom Hinge Sleeve

Order: 1 - 000,005,62x.x6 w/a bottom hinge  
1 - 900,502,56x.x1 sleeve, bottom hinge

## To Install:

1. Open main door.
2. Have someone assist you in removing the main door.
3. Locate the hinge pocket cover in the top left, front corner of the cabinet. Remove the hinge pocket cover.
4. Locate the two (2) nuts from the top hinge carriage bolts in the hinge pocket and remove.
5. Close the main door so it rests on the door rollers.
6. Have someone hold the door in place.
7. With someone holding the door in place, remove the three (3) hex bolts which secure the top hinge to the cabinet.
8. Lift the door off the bottom hinge.
9. Remove the flanged bushing from the bottom of the door.
10. Remove the bottom hinge by removing the two hex bolts securing it.
11. Install the new hinge provided in the kit and secure.
12. Install new sleeve (with the washer side down) over the hinge pin.
13. Replace the door by lifting the door and aligning the hole in the bottom of the door with the new pin sleeve.
14. Be careful not to get fingers, hands, or feet in the way and lower main door on the hinge pin sleeve.
15. Secure top hinge back to cabinet.
16. Be sure to check alignment of the T-handle stud with nut retainer housing.

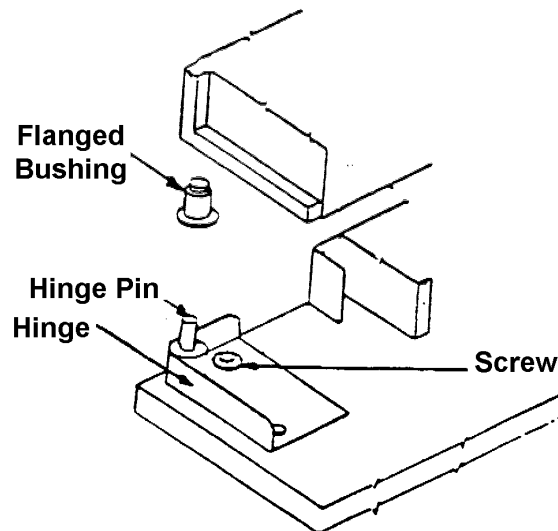

# ANTI-VANDAL SLEEVE / HINGE KIT PRIOR TO 0001-3049BM (INCLUDES 3057CM AND 3058CM)

## Top Hinge Sleeve

Order: 1 - 905,502,55x.x1 Top Hinge Sleeve

### To Install:

1. Open the main door.
2. Remove screw A (see figure 1) and collar from hinge pin. *Note: Discard collar.*
3. Locate the hinge pocket cover on the top left, front corner of the cabinet. Remove the hinge pocket cover.
4. Locate the two (2) keps nuts on the carriage bolts in the hinge pocket and remove.
5. **Have someone hold the main door before continuing for safety.**
6. Loosen the three (3) hex bolts which secure the top hinge to the cabinet.  
*Important: Loosen, do not remove.*
7. Slide the top hinge sleeve (the new sleeve with a hole in it) over the top hinge pin.
8. Secure the new top hinge sleeve with screw A removed in step 2.

